

#120203

Tech. Spec

Internal Gear Ratio: 2.92 (38/13)
 Total Gear Ratio: 7.01:1 (Pinion 30 / Spur 72)
 Module: 48 DP
 Shockoil: Front WT50 - Back WT50

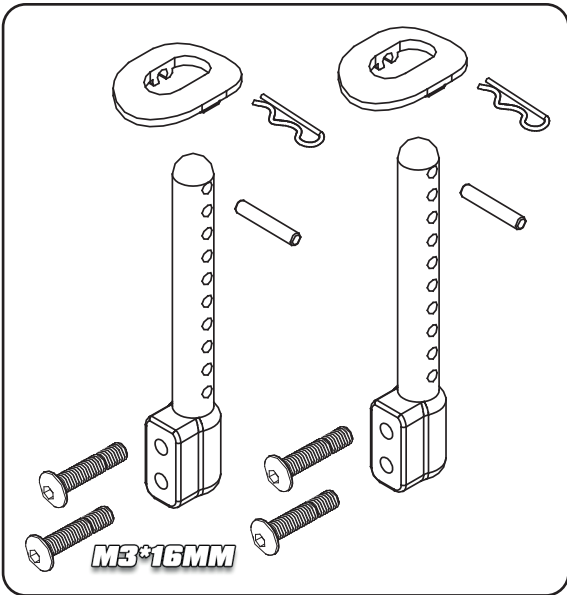

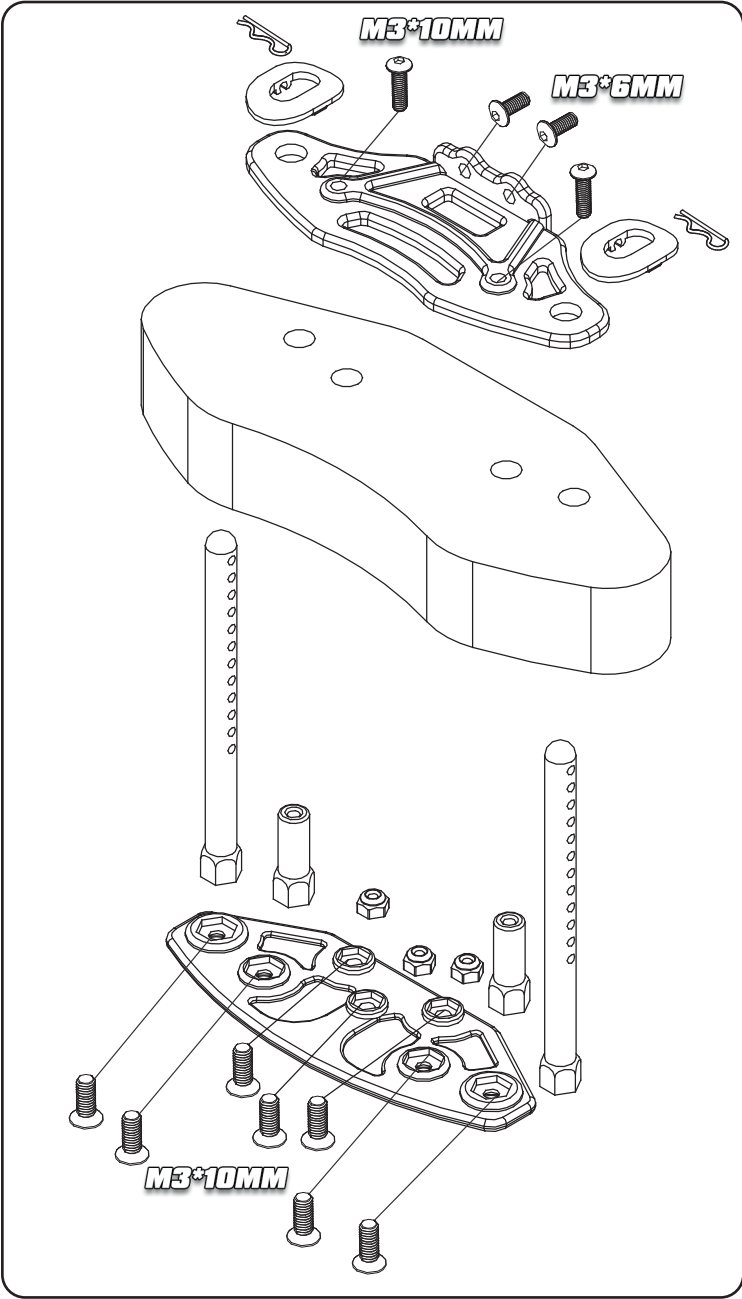

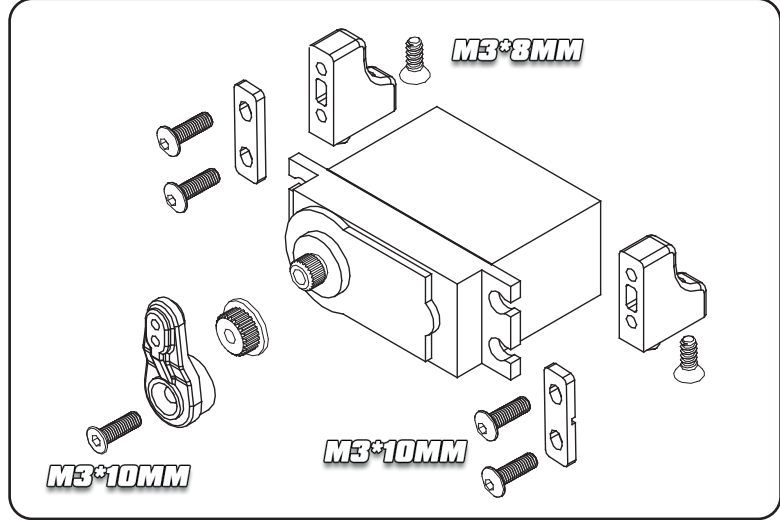
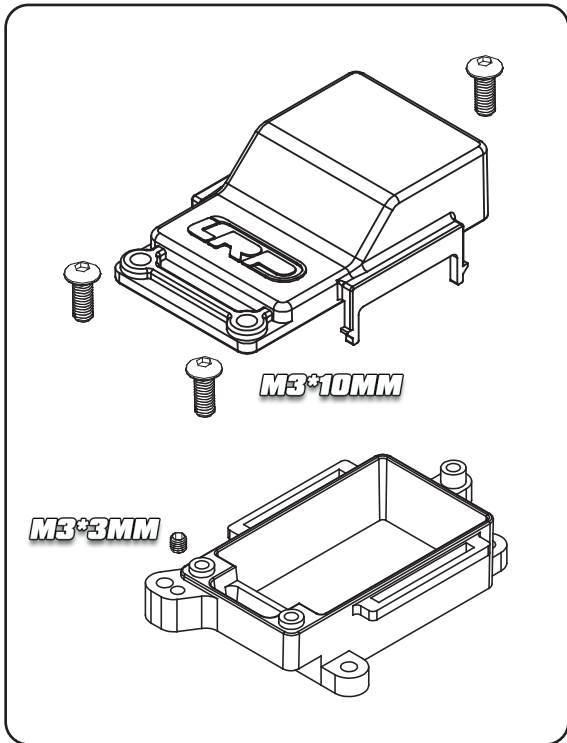
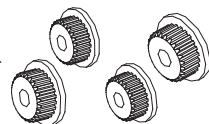

Servohorn - Adaptor

S/K/J = **23Z|23T** - Sanwa / Kopropo / JR
 H = **24Z|24T** - HiTEC
 F = **25Z|25T** - Futaba
 Z = **26Z|26T** - Others



Accessories Bag

- 120959**  M3x6mm Rundkopfschraube
M3x6mm Button Head Screw
- 120958**  Motorschrauben
Motorscrews M3x8mm Rundkopfschraube
M3x8mm Button Head Screw
- 120957**  M3x10mm Rundkopfschraube
M3x10mm Button Head Screw
- 120955**  M3x16mm Rundkopfschraube
M3x16mm Button Head Screw
- 120954**  M3x8mm Senkkopfschraube
M3x8mm Countersunk Screw
- 120953**  M3x10mm Senkkopfschraube
M3x10mm Countersunk Screw
- 120948**  M3x3mm Madenschraube
M3x3mm Set Screw
- 122230**  Motorritzel / Pinion Gear
30Z | 30T